

Prizelawn®
COMMERCIAL BROADCAST SPREADER

Model: CBRIV
Model: CBRIVSS

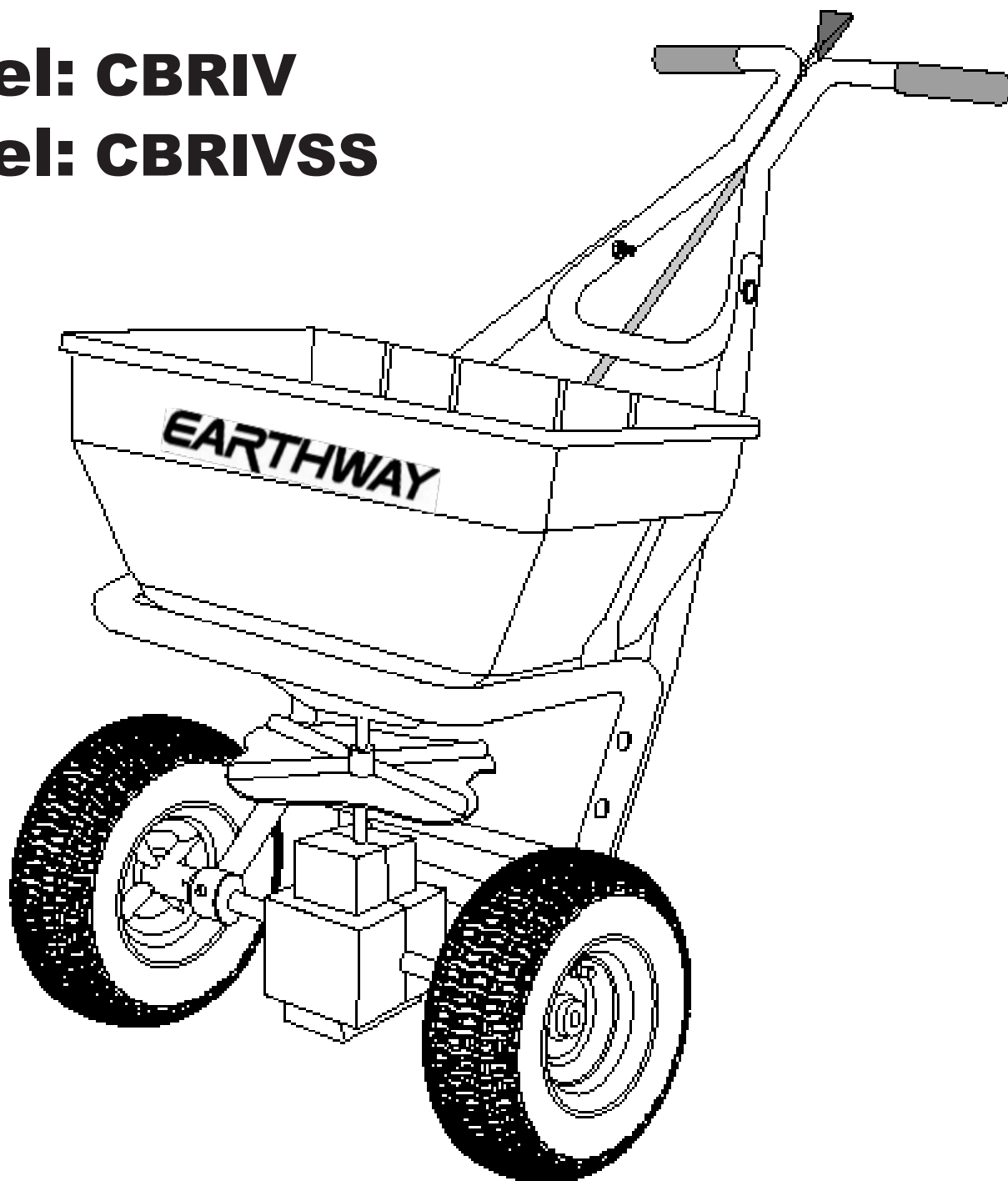

Owner's Manual

ASSEMBLY INSTRUCTIONS

1. Remove the spreader and components from carton and place hopper up-side down on a padded surface as shown. Slide drive and free wheel onto axle as shown with the long portion of wheel hub facing the frame. Both wheels are identical to ease assembly. Secure free wheel with Spring pin through the axle only. Attach drive wheel to axle Hog ring through the wheel hub and the axle.

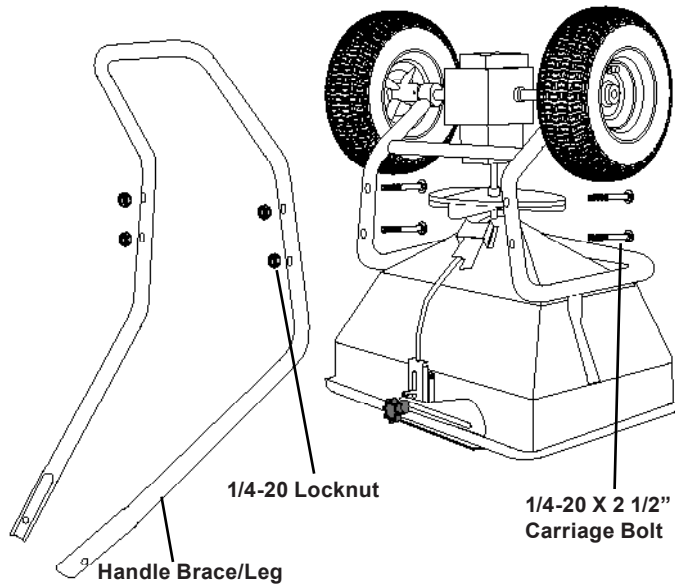
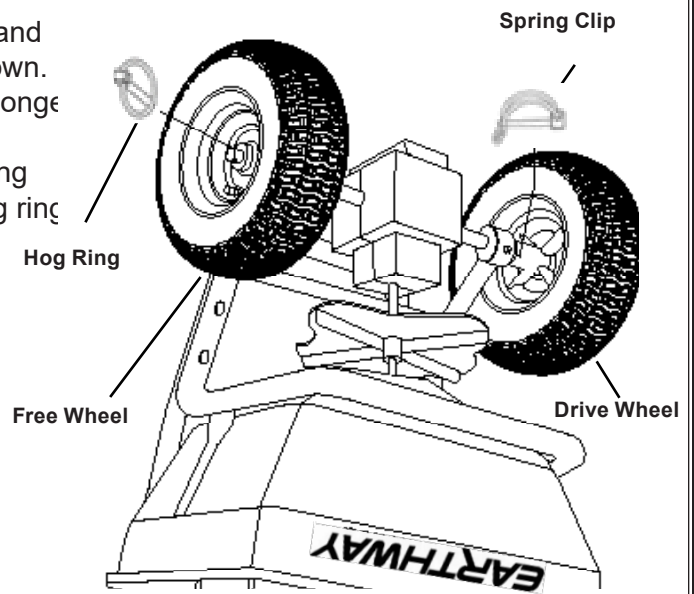

2. Attach leg/brace to frame as shown using (4) 1/4-20 x 2 1/4" carriage bolts and locknuts.

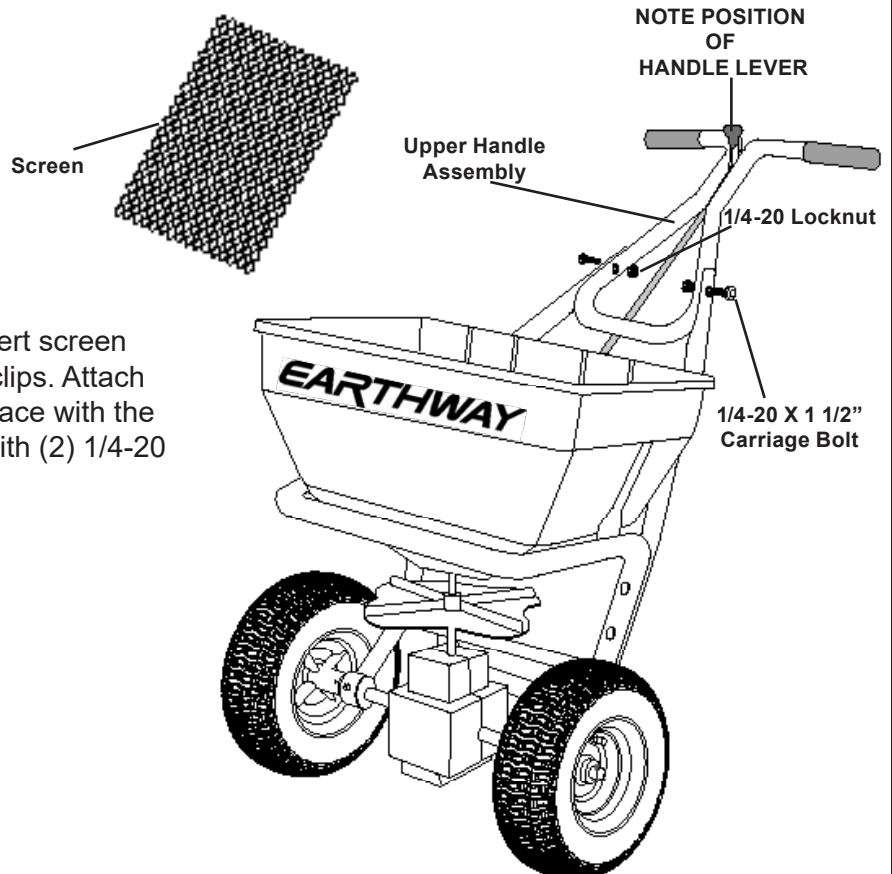

3. Turn spreader upright on wheels. Insert screen into hopper sliding it under the screen clips. Attach the upper handle assembly to handle brace with the handle lever facing as shown. Secure with (2) 1/4-20 x 1 1/2" carriage bolts, and locknuts.

ASSEMBLY INSTRUCTIONS

4. Install control rod to handle lever with a 1/4" dia. clevis pin. Thread (1) 5/16" hex nut onto the control rod until it is roughly in the middle of the threaded area.

5. Slide the end of the control rod through the L-Bracket making sure there no tension between the hex nut and the L-Bracket. Set the rate control plate to the "B Position". Flip control lever to the "On Position". Check port gap. Adjust the threaded nut on the threads until the port opening is "just" open when lever is in the "On Position". With the lever in the closed position install the second 5/16 Hex Nut on the control rod. Tighten both nuts against the L-Bracket.

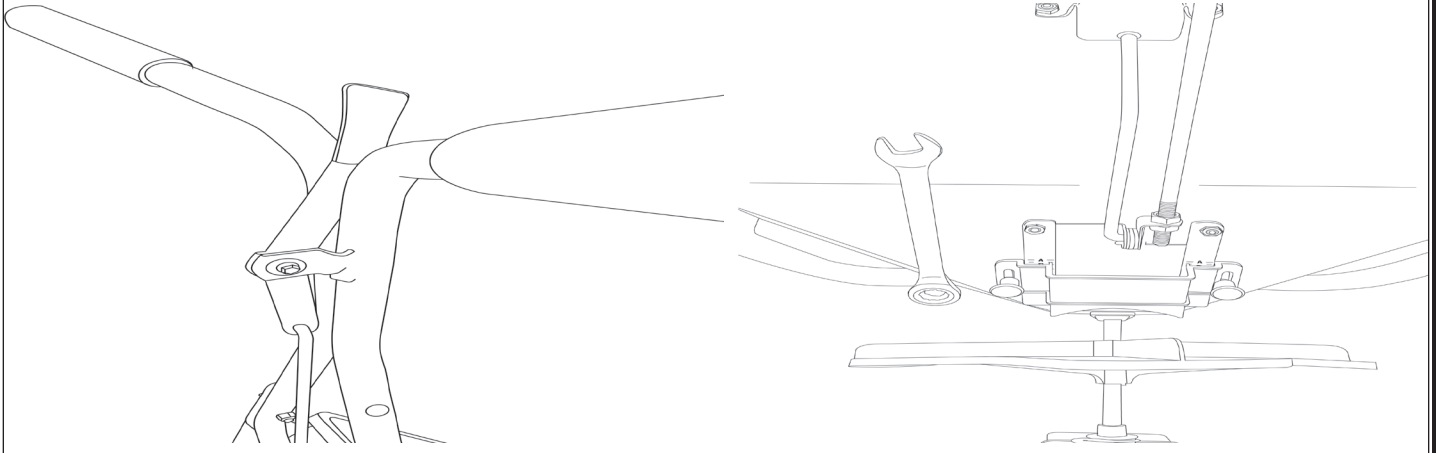

OPERATION

1. Check the product package for the rate setting, and recommended swath width. Loosen rate control knob and slide rate plate to the proper setting. The pattern is controlled by loosening the two knobs on the discharge chute and moving the chute closer or farther away from the impeller (setting A, B, or C). See "**PATTERN ADJUSTMENT**" for details on the following page.

2. Always fill the spreader on the driveway or sidewalk not on the lawn. Make sure screen is in hopper and spreader is in the "**OFF**" position.

3. Start spreader moving before opening port. Close before stopping. Always push spreader, never pull.

4. Hold handle so top of spreader is level. Tipping the spreader too far can cause uneven spreading.

5. The settings and swath widths on the product label are recommended starting points. Always check the delivery rate and pattern on a small area before treating a large area. Actual delivery rate can vary due to weather conditions, operating variables, and condition of the product being applied. See "**HOW TO DETERMINE SPREADER SETTINGS AND SPREAD WIDTH**" for details.

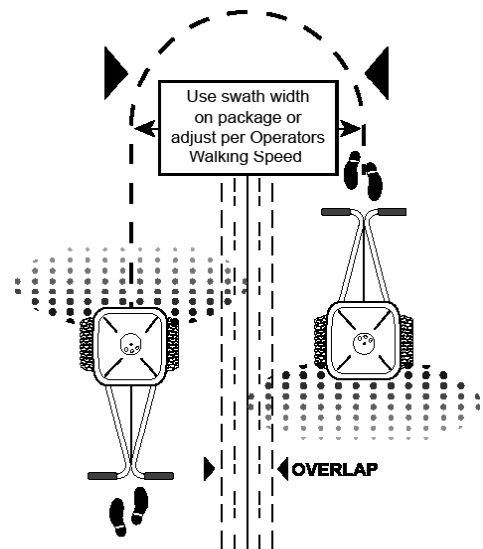

6. Push spreader at a normal walking speed 2 1/2 m.p.h. (18 feet in 5 seconds). Apply header strips around area to be treated. Space trips across the area as shown. Keep material off flower beds, sidewalks, etc.

7. When transporting spreader, make sure that it is in the "**OFF**" position.

8. Empty spreader after each use. Return leftover material to its original container.

PATTERN ADJUSTMENT

Normal spreading of materials requires no adjustment (factory setting "A") unless stated on the package. In those cases where the spread pattern has shifted, the pattern can be adjusted left and right by loosening the two knobs on the discharge chute and moving the chute closer or farther away from the impeller. Settings of "A, B, and C" are provided as reference.

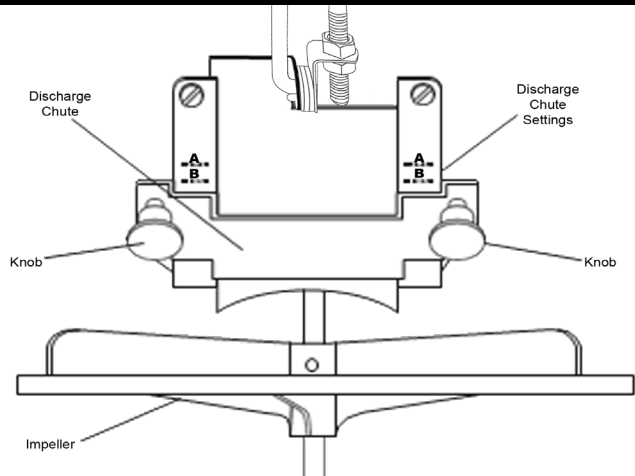

HOW TO DETERMINE SPREADER SETTINGS AND SPREAD WIDTH

Two major factors should be considered when determining correct spreader settings of any product:

1. The product application rate, or the amount of material applied per 1,000 square feet.
2. The effective pattern width, or the actual width in which material is applied. Label settings are a guide and can be affected by numerous factors.

EFFECTIVE PATTERN WIDTH

A simple visual pattern test can be made by operating the spreader over a non-turf area and evaluating the pattern.

A more accurate method is to place a row of common, disposable, aluminum cake pans approximately 1 foot on centers. Set the rate plate at a middle setting and make 3 or 4 passes in the same direction as shown. Pour the material collected from each pan into individual bottles of the same size. Set them side by side in order, and visually inspect their volume. If the pattern is not centered (example: volume in bottle #2 left not equal to bottle #2 right), adjust the discharge chute up or down as described in "**PATTERN ADJUSTMENT**" section above.

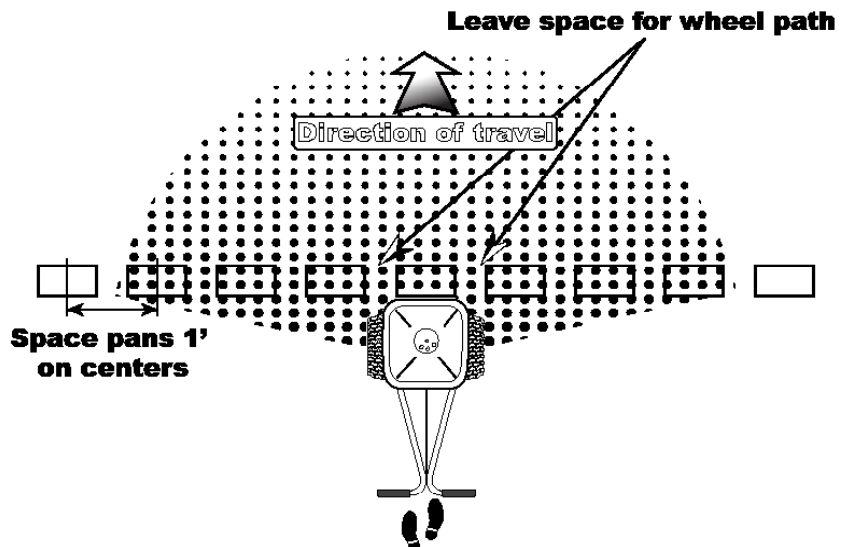

Once the pattern is uniform, the effective pattern width can be determined. The effective pattern width is the distance out from the spreader to a point where the amount of material is 1/2 the average amount in the center pans. This distance is multiplied by 2 to achieve the total effective pattern width.

APPLICATION RATE

Knowing the effective pattern width (for example, 10 feet), measure a distance equal to 100 square feet (10' x 10' swath width). Determine the product coverage in pounds / 100 sq. ft. by taking the weight of the product and dividing it by the recommended square foot coverage (add two zeroes to the weight of the bag).

EXAMPLE:

Product weight: 25 lbs.
 Sq. ft. coverage: 5,000 sq. ft.
 2500 lbs. ÷ 5,000 sq. ft.
 = .5 lbs. / 100 sq. ft.





Weigh 15 to 20lbs. of material and spread over the 100 sq. ft. area. Weigh remaining material left in hopper and adjust rate setting as required. Repeat test until application rate is correct.

RATE SETTING CONVERSION

The following provides approximate Prizelawn® CBR IV/CBR IVSS settings for those units listed.

Brand/Model																										
PRIZELAWN CBRIV/ CBRIVSS	B	C	D	E	F	G	H	I	J	K	L	M	N	O	P	Q	R	S	T	U	V	W	X	Y	Z	
EARTHWAY	5	—	—	—	10	—	—	—	—	15	—	—	—	—	20	—	—	—	—	25	—	—	—	—	30	
Spyker 76/78-2	—	3	—	—	—	4	—	—	5	—	—	6	—	—	7	—	—	8	—	—	—	9	—	—	10	
LESCO #029600	—	B	C	D	—	E	F	—	G	H	I	—	J	K	L	—	M	N	O	—	P	Q	R	—	S	
The Andersons SR2000/AP2000	D	E	F	G	H	I	J	K	L	M	N	O	P	Q	R	S	T	U	V	W	X	—	Y	Y	Z	
Scotts	—	—		2	—	—	3	3.5	—	4.5	5	5.5	6	—	6.5	—	7	—	7.5	—	8	—	8.5	—	9	

The following provides approximate Prizelawn® CBR IV/CBR IVSS settings when only the product weight, square foot coverage, and visual inspection of the material is available.

FERTILIZER	BAG RATE Pounds of fertilizer used per 1,000 sq. ft. of coverage	APPROXIMATE SETTING	SPREAD WIDTH (IN FEET)
Large, heavy particles 	5 10 15	M O Q	8 8 8
Medium, mixed particles 	5 10 15	L N O	8 8 8
Small particles (Nitrogen) 	1 2 3	G J L	8 8 8
Mixed size particles Some fines 	5 10 15	M O P	6 6 6
Lightweight particles 	5 10 15	J L O	4 To 6

CALIBRATION INSTRUCTIONS

The Prizelawn® CBR IV/CBR IVSS was factory calibrated, however calibration should be checked occasionally to assure optimum performance.

1. Pull the on/off lever to the “OFF” position. Set the rate control plate to setting “B”.

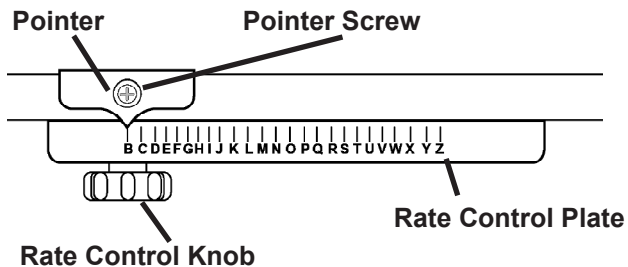

2. Flip on/off control lever to the “ON” position. Check the port opening. It should be just open. If adjustment is necessary, continue to step #3.

3. Loosen the rate control knob and slide the rate plate until the port is just opening. Loosen pointer screw and move pointer until it aligns with “B” on the rate plate. Retighten pointer screw.

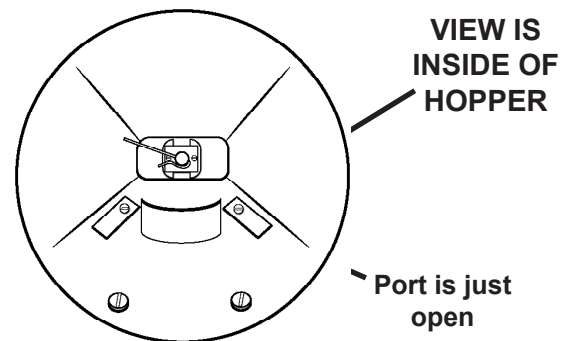

WARRANTY

One Year Limited Warranty

EarthWay Products, LLC. provides this limited warranty that this product is free of defects in original workmanship and materials for a period of one year to the end user with the original purchase receipt. If a manufacturing non-conformance is found, EarthWay Products, LLC. at its discretion will repair or replace the part(s)/product at no charge provided the failure is not the result of incorrect installation, mishandling, misuse, tampering, improper storage, or normal wear and tear as determined by EarthWay. Due to the corrosive nature of most fertilizers and ice melt products, EarthWay Products, LLC. makes no warranty against and specifically excludes part(s) or product degradation or failure due to corrosion or its effects.

EarthWay at its discretion may require that the part(s) or product be returned along with the original purchase receipt for examination and compliance with the terms of this limited warranty. Do not return any product without first receiving authorization from EarthWay Products, LLC. IN NO EVENT SHALL EITHER PARTY BE LIABLE TO THE OTHER FOR SPECIAL, INDIRECT, INCIDENTAL, OR CONSEQUENTIAL DAMAGES, EVEN IF SUCH PARTY SHALL HAVE BEEN ADVISED OF THE POSSIBILITY OF THE SAME.

To seek remedy under this limited warranty, contact EarthWay Products, LLC. at support@earthway.com or write to EarthWay Products, LLC. 1009 Maple Street, Bristol, IN 46507, and describe the nature of the manufacturing defect. SPECIFIC LIMITATIONS: This limited warranty covers only the part(s) or product; any labor charges associated with the repair or replacement of non-conformances are specifically excluded.

The above-listed warranty procedure is a condition precedent to bringing any legal action to enforce this limited warranty. Any action to enforce any portion of this limited warranty must be commenced within ninety days after the expiration of the limited warranty coverage period. Any performance of repairs will not suspend this limitation period from expiring unless state law provides otherwise. Any performance of repairs after the limited warranty coverage period has expired, or performance of repairs regarding anything excluded from coverage under this limited warranty shall be considered “goodwill” repairs, and they will not change the express terms of this limited warranty or extend the limited warranty coverage period.

Exclusive jurisdiction for deciding legal disputes relating to alleged breach of warranty or representations of any nature relating to this limited warranty must be filed in the courts of Elkhart County within the State of Indiana. Any and all claims, controversies, and causes of action arising out of or relating to this limited warranty, whether sounding in contract, tort, or statute, will be governed by the laws of the State of Indiana, without giving effect to any choice or conflict of law provision or rule.

NO OTHER WARRANTY, EXPRESS, IMPLIED, OR STATUTORY, SHALL APPLY, INCLUDING, BUT NOT LIMITED TO, ANY IMPLIED WARRANTY OF MERCHANTABILITY, APPLICATION, OR FITNESS FOR A PARTICULAR PURPOSE, OR ANY OTHER WARRANTY OBLIGATION ON THE PART EARTHWAY, AND ALL SUCH WARRANTIES ARE EXPRESSLY DISCLAIMED. In the event that applicable law prevents the disclaimer of any implied warranties, then such implied warranty shall be limited to the fullest extent permitted by law. Without limiting the foregoing, if applicable prevents the disclaimer of any such implied warranties, this limited warranty limits the period of time in which a claim for breach of implied warranties, including but not limited to the implied warranty of merchantability or fitness for a particular purpose, may be filed. In such event, any claim for breach of implied warranty must be brought before the expiration of this express limited warranty's one-year term.

PARTS LIST for CBR IV & CBR IVSS

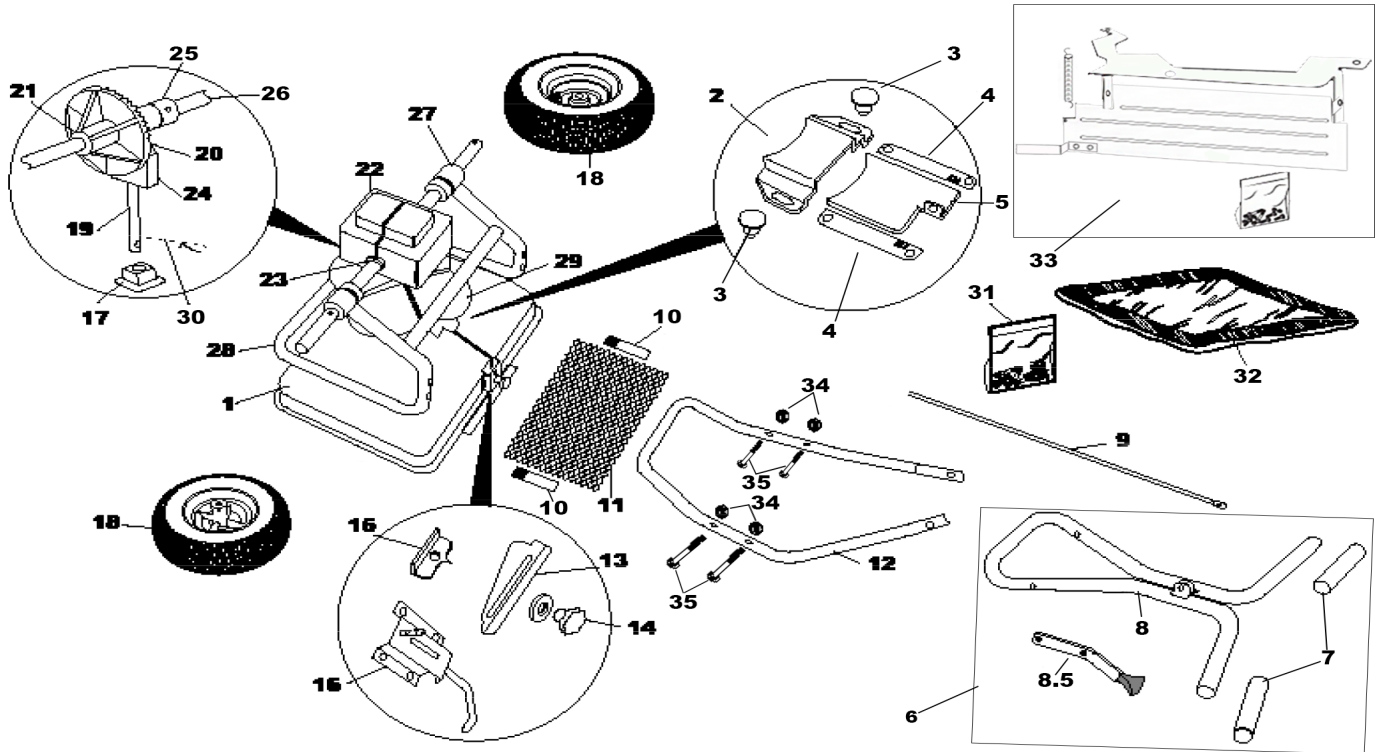

Key	Description	CBR IV	CBR IVSS	Key	Description	CBR IV	CBR IVSS
1	Hopper	60454		18	Drive Wheel & Free Wheel	P790120W	
2 & 4	Discharge Chute & Shut-Off Plate Guides*	P15144-04		19	Impeller Shaft	P15641	
3	Discharge Chute Knob	P14001		20	Pinion Gear	P14833	
				21	Axle Gear	P14832	
6	Upper Handle Assembly (7-8.5)	P15512-04		22	Gear Cover (Half)	P15753	
7	Handle Grip	P14870		23	Gear Cover Clamp	P14868-1	
8	Upper Handle	P15511-04	P15498	24	Gear Support	P14834	
8.5	Handle Lever	44301		25	Axle Collar w/Set Screw	P780200	
9	Control Tube	79002		26	Axle	P15518	
10	Screen Clip	P14022		27	Axle Bearing (4)	P16412	
11	Hopper Screen	18128		28	Frame Assembly	P15517	P15516-04
12	Handle Brace/Leg	P15507		29	Impeller	P14625	P15517
12	Handle Brace/Leg	P15507-01	P15508-J131	30	Agitator	33117	
13	Rate Plate	P15521-04s		31	Fastener Package	P15579	
14	Rate Control Knob	P12704		32	Hopper Cover	P14606-1	
15	Pointer	P12708-04		33	OPTIONAL Deflector Assembly	P15681	
16	Spring Housing Assembly	P15527-04		34	Nut 10-24 Hex SS J214	P90027	
17	Impeller Shaft Bearing	P14312-1		35	Bolt 1/4-20 X 2-1/2" Carriage	PJ565	

OPTIONAL ACCESSORIES

for CBR-IV & CBR-IVSS

P15681 Operation

The deflector can be placed in two positions. The **ON** position (down) or the **OFF** position (up). To operate, simply rotate the deflector plate downward to the **ON** position using the kick plate. The spring will automatically pull the plate down and hold it. Reverse the procedure to position the deflector plate in the **OFF** position (up).

In the **ON** position, the material exiting the right hand side of the spreader is deflected as shown. This allows the spreader to be butted up against a sidewalk, driveway, lot line, etc. minimizing the amount of material thrown into these areas.

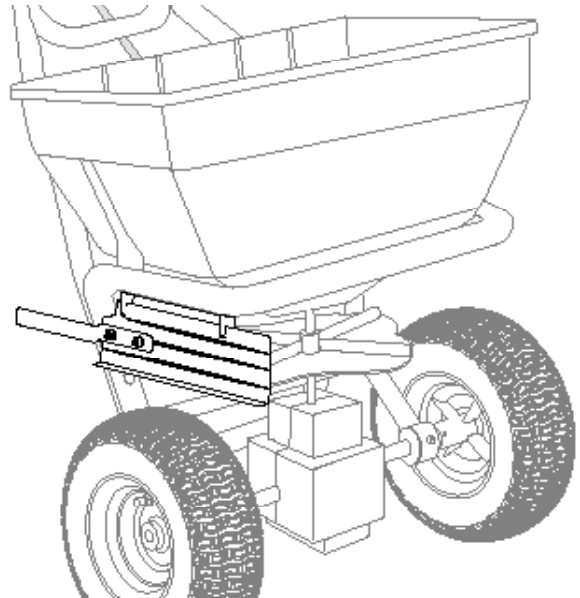

MAINTENANCE

- 1.** Never store material in spreader. Return unused product to its original container.
- 2.** Wash spreader thoroughly after each use and dry completely in the sun or heated area.
- 3.** Grease axle bearings on the frame. Oil the impeller shaft bearing in hopper, pivot points on the shut-off linkage and the spring in the housing under the rate plate.
- 4.** Remove the gear cover and wash gears thoroughly and oil all bearing areas as shown. Re-install gear cover.
- 5.** Gear mesh should be checked on a regular basis during high use periods. Clearance between the axle gear and pinion gear should be minimal but not tight. If adjustment is necessary, loosen axle collar set screw and hold the gears together. Slide the axle collar against gear support and tighten axle collar set screw. Spin drive wheel. Gears should run freely and smoothly.
- 6.** Impeller surface should be cleaned periodically to remove build-up of product. Build-up can cause the spread pattern to change.
- 7.** Tire pressure should be 20-25 PSI

